

Unitronics VFD Quick Start Guide

Motor Wiring

There are 2 wiring options; the wiring is determined by the grid voltage. The motor voltage should be \leq Grid voltage (See Image 2).

Star: Connect the starting or finishing ends of three coils together to form the neutral point. A common wire, Neutral is taken out from the neutral point.

Delta: Delta winding allows third-harmonic currents to circulate within the transformer, and prevents third-harmonic currents from flowing in the supply line. Delta connected windings are not commonly used for higher transmission voltages (138 kV & above).

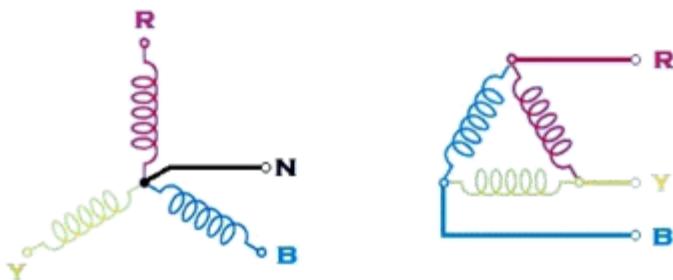

Important wiring guidelines:

- Always connect the 3 terminals SG, D + and D- along the entire RS485 network even if it is more than a single VFD.
In Vision controllers the pin SG (Signal Ground) is the 0V reference.
On the VFD side the SG is the COM signal.
- A shielded twisted RS485 cable should be used and the shield should be connected on one side. This is especially important in a system where the cable is routed from cabinet to cabinet.
In a system with UniStream the cable shielding on the side of the controller must be connected to the FG terminal in the 4-pin connector.
In a system with Vision/Samba the cable shielding must be connected to the PE terminal of the first VFD (closest physically to the controller).
- The PE terminal of the VFD must be connected to the COM signal. This wire must be connected separately as indicated in the drawing.
This connection must be made in all VFD units on the same network even if there is more than one VFD.
However, there may be cases where it is necessary to try to disconnect this signal and leave it connected only in a single VFD.

- The connections of the FG and PE intended for resistance to EMI are a recommendation and there may in practice be cases where it would be better to disconnect them.
The need for this connection depends on the distance between the controller and the VFD and / or the quality of the grounding.
- It is mandatory to connect the PE (Protective Earth) trigger of the VFD and the motor body to the grounding of the structure.
This is a Safety requirement and is not related to EMI durability.
- Make sure that the last communication loop VFD 120OHM termination is on (right DIP switch or jumper is UP) and for all the other VFD's are off (right DIP switch or jumper is DOWN), as additional check measure the resistance between the 485+ and 485- terminals on the PLC and make sure that the value is 600OHM.
- Ground the UniStream PLC with shortest possible way.
- Separate the VFD and PLC ground points.
- In order to reduce noise disturbance, we highly recommend to use 19,200 bps baud rate on the RS-485 network.

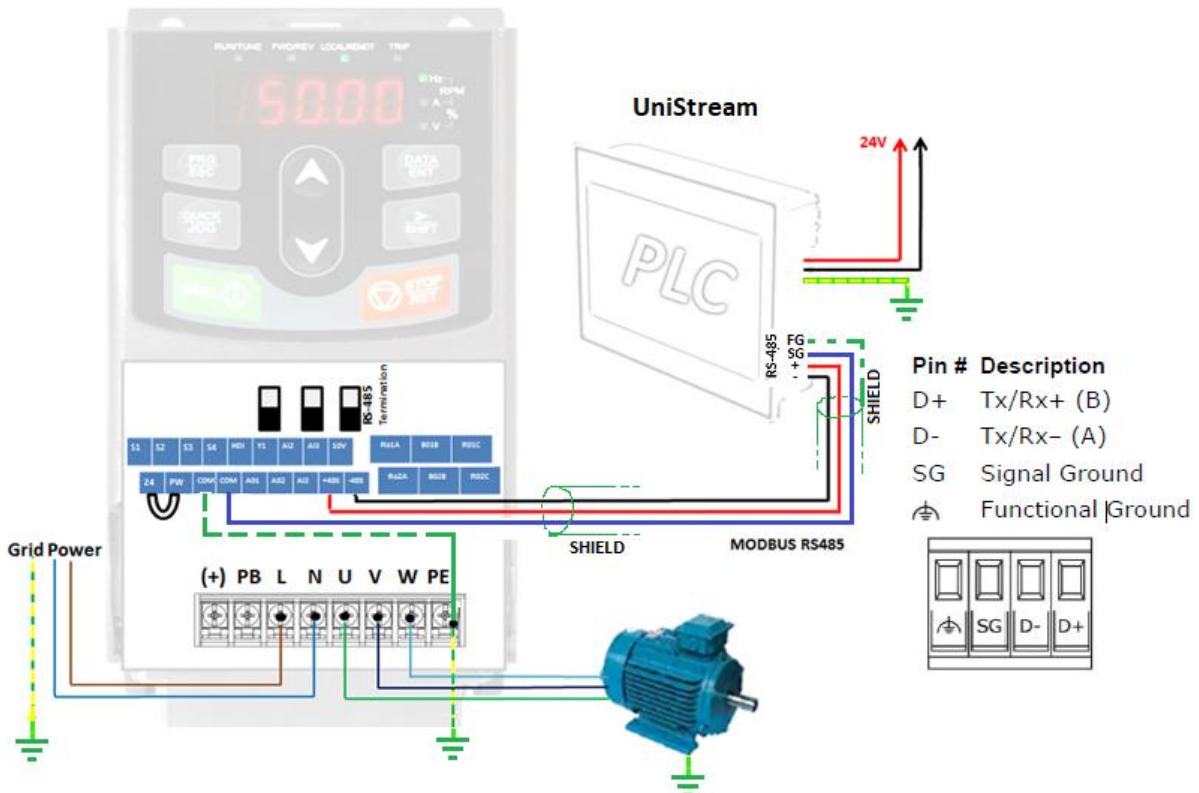

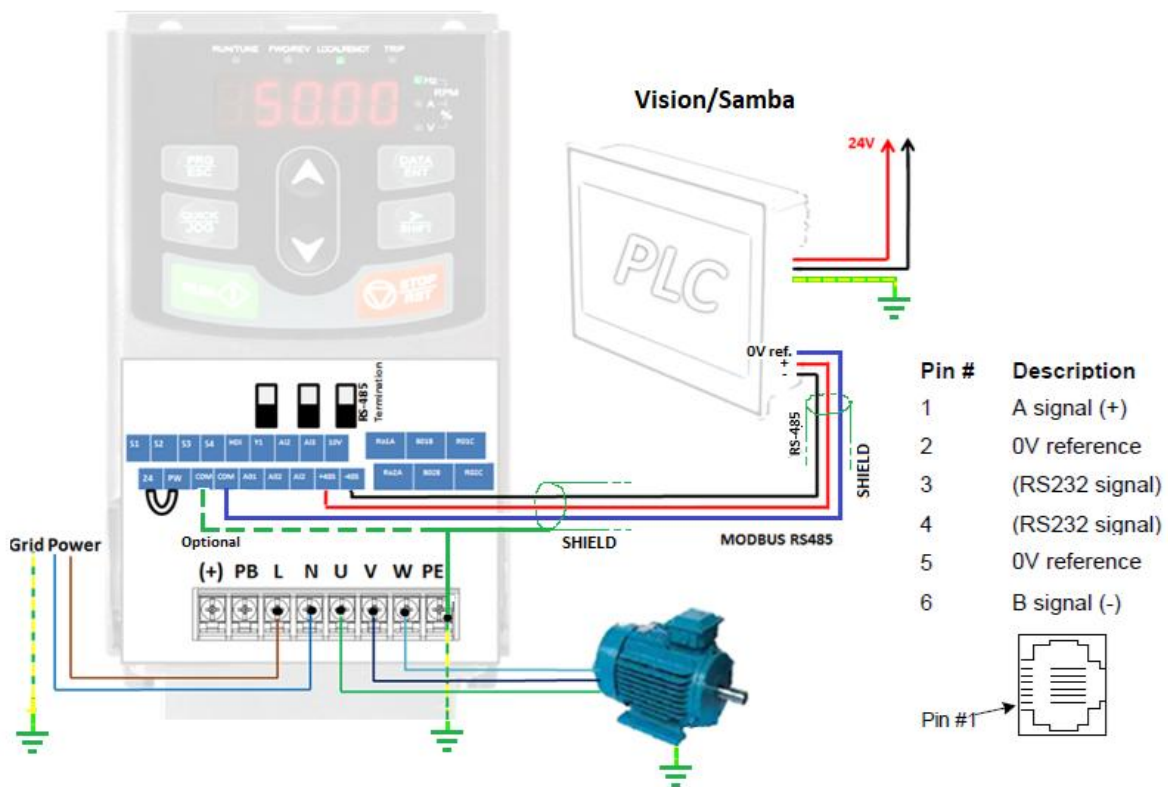

VFD Configuration

The following image shows you how to use the VFD Keypad.

Name	Description		
Buttons		Programming key	Enter or escape from the first level menu and remove the parameter quickly
		Entry key	Enter the menu step-by-step Confirm parameters
		UP key	Increase data or function code progressively
		DOWN key	Decrease data or function code progressively
		Right-shift key	Move right to select the displaying parameter circularly in stopping and running mode. Select the parameter modifying digit during the parameter modification
		Run key	This key is used to operate on the inverter in key operation mode
		Stop/Reset key	This key is used to stop in running state and it is limited by function code P07.04 This key is used to reset all control modes in the fault alarm state
		Quick key	The function of this key is confirmed by function code P07.02.

Configure the Motor Parameters:

P02.01 – Rated power of asynchronous motor [KW].

P02.02 – Rated frequency of asynchronous motor

P02.03 – Rated speed of asynchronous motor [RPM]

P02.04 – Rated voltage of asynchronous motor [V] P02.05 – Rated current of asynchronous motor [A]

IP55	IK08	ICL F	40°C	S1	79.6 %	cos φ	kg 11	IE2
Δ	230	50	1400	0.72	0.75	3.15		
Y	400	50	1400	0.72	0.75	1.81		
Δ	280	60	1680	0.72	0.76	2.37		
Y	480	60	1680	0.72	0.76	1.46		
DE	6204			g	NLGI GLEM2			
NDE	6204			h				

Image 2

Get the Motor Moving

Set the Run command channel source

The VFD offers 3 ways to select the RUN command:

- Keypad- set P00.01 to 0.
- Terminal- set P00.01 to 1 MODBUS- set P00.01 to 2

Frequency Source Command

Frequency is set via P00.06.

Change the frequency via:

1. Keypad- set P00.06 to 0 Keypad Arrows.
2. Terminal*- set P00.06 to 1 potentiometer wheel from keypad.
3. MODBUS- set P00.06 to 8 via RS485. Note - Frequency can be also controlled via Analog , high speed input etc...

Auto Tuning

Motor parameter autotuning is required when using sensorless vector mode. (P00.00 = 0 or 1)

Autotuning is set via P00.15

0: No operation.

1: Rotating autotuning Comprehensive motor parameter autotune. It is recommended to use rotating autotuning when high control accuracy is needed.

2: Static autotuning 1 (autotune totally) It is suitable in the cases when the motor cannot decouple from the load. The autotuning for the motor parameter will impact the control accuracy.

3: Static autotuning 2 (autotune part parameters); when the current motor is motor 1, autotune P02.06, P02.07, P02.08

Communication Parameters via MODBUS:

Modify these parameters according to your requirements:

1. Set P14.00 (local communication address) to the inverter ID number (1 -247)
2. P14.01 (communication baud ratio)
3. P14.02 (Digital bit checkout).

Note - Default settings: ID=1, Baud rate=19200, Digital bit checkout =Even, 8, 1

The same baud rate and digital bit should be configured in the VFD Properties in UniLogic/VisiLogic.

Terminal

In case you wish to send commands to the VFD via the terminal (IO) connect the PLC digital outputs to the VFD digital inputs (S1-4).

Note- the connection can be wired as Source or Sink (default).

Use a U-shaped contact tag to set NPN or PNP mode, and the internal or external power supply. The default setting is NPN internal mode.

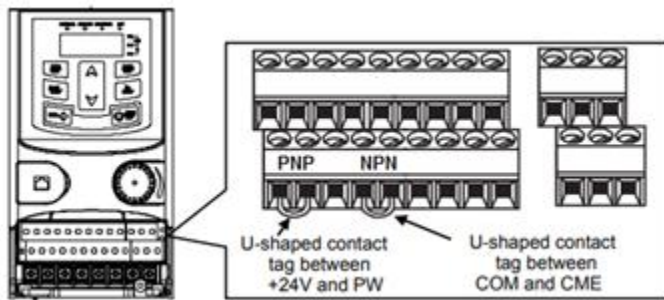

Image 3 *

Image3 example for UMI-B1 UL Series.

Example settings:

- **Forward** - P05.01 (S1 terminals selection) to 1.
- **Reverse** - P05.02 (S2 terminals selection) to 2.
- **Forward jogging** - P05.03 (S3 terminals selection) to 4.
- **Reverse jogging** - P05.04 (S4 terminals selection) to 5.

Note - The terminal selection can be modified. For more options, please see VFD User manual.

Reset the VFD to factory defaults

To restore factory defaults, write the value 1 to P00.18.

Please note that:

1. The motor **parameters** in group will not reset.
2. The communication parameters will reset only after power up.

Terminal Dip switches

Above 2.2KW:

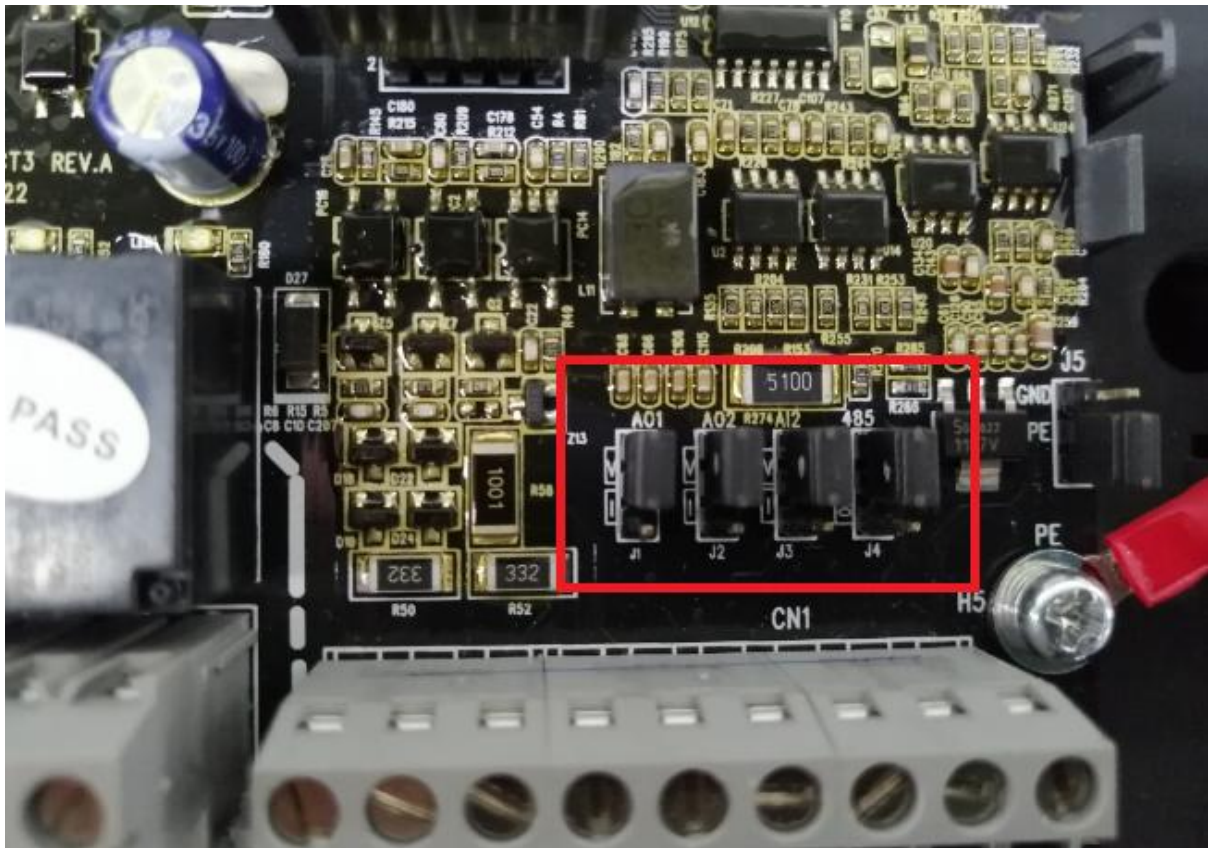

Below 2.2KW:

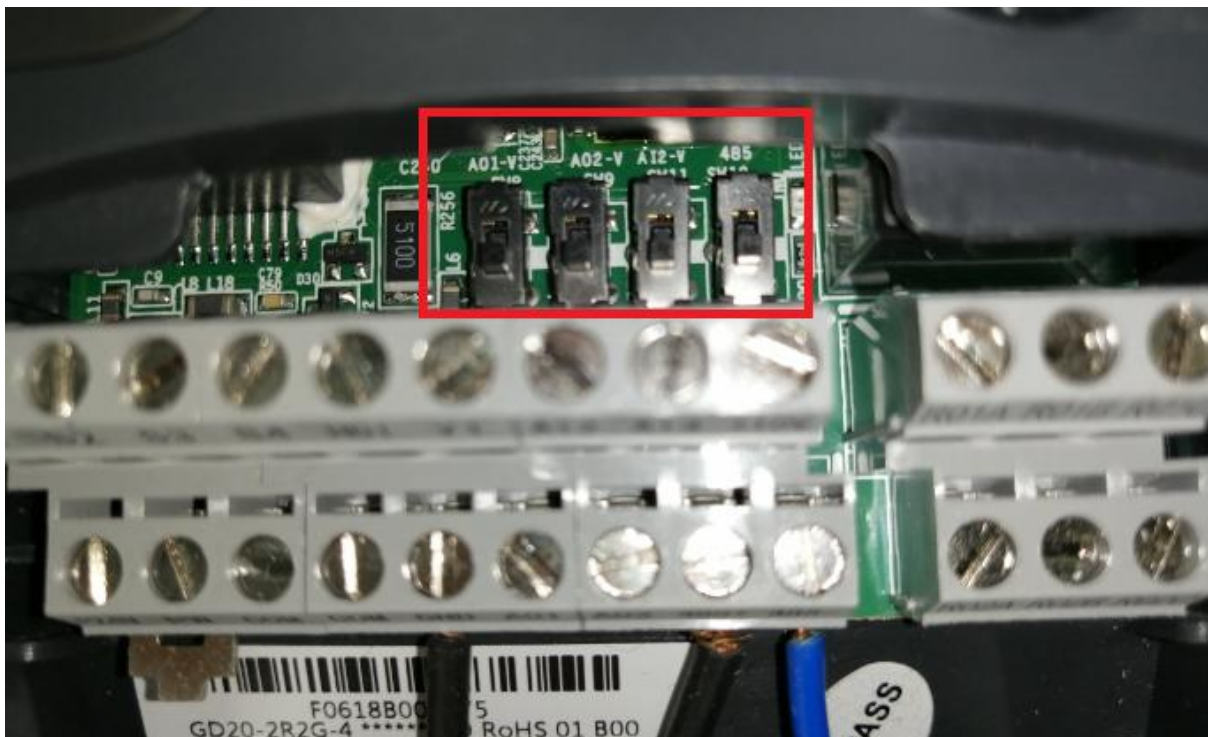

Guy Sela
Unitronics